

Features

- 1-channel signal conditioner
- Universal usage at different power supplies
- Dry contact or NAMUR inputs
- Input frequency 1 mHz ... 12 kHz
- 2 relay contact outputs
- Start-up override
- Configurable by keypad
- Line fault detection (LFD)
- Up to SIL 2 acc. to IEC 61508/IEC 61511

Function

This signal conditioner monitors an overspeed or underspeed condition of a digital signal (NAMUR sensor/mechanical contact) by comparing the input frequency to the user programmed reference frequency.

An overspeed or underspeed condition is signaled via the relay outputs. Line fault detection of the field circuit is indicated by a red LED and relay. The startup override feature sets relay outputs to default conditions programmed by the user for up to 1,000 seconds.

The unit is easily programmed by the use of a keypad located on the front of the unit.

n, refer to the manual and

Assembly

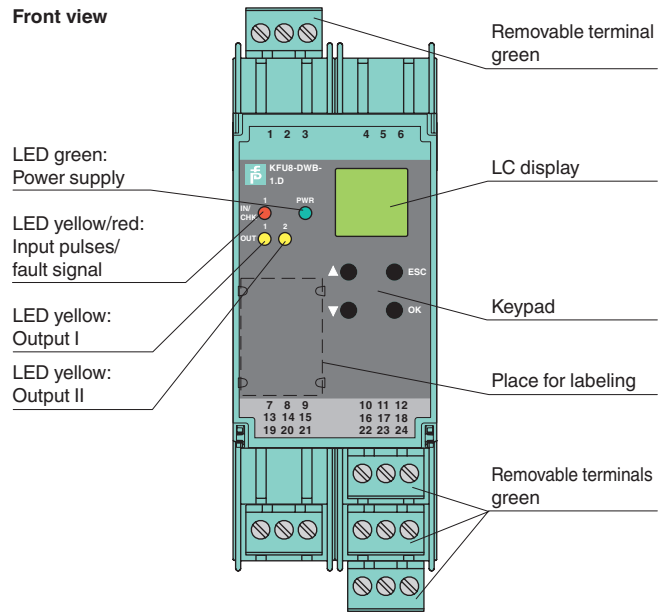

SIL 2

Connection

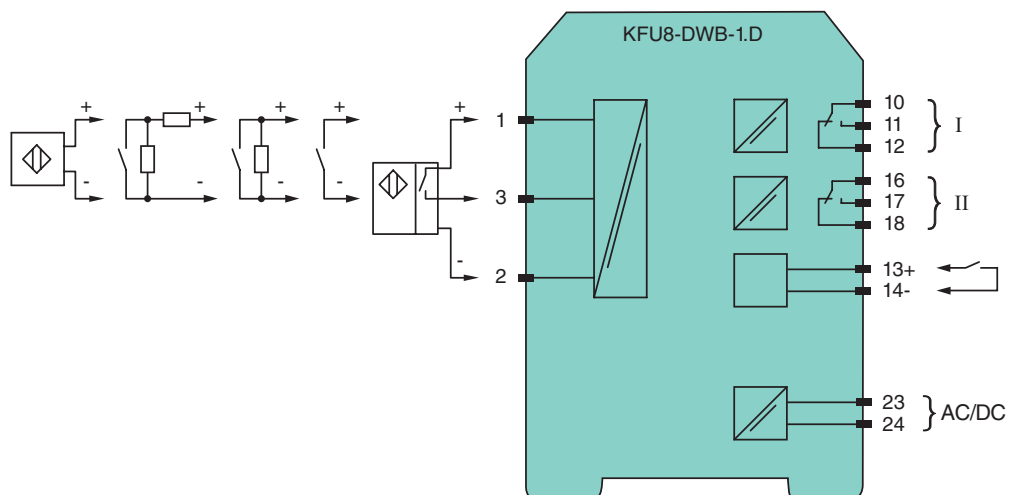

Release date 2017-09-12 15:15 Date of issue 2018-08-22 231209_eng.xml

General specifications	
Signal type	Digital Input
Functional safety related parameters	
Safety Integrity Level (SIL)	SIL 2
Supply	
Connection	terminals 23, 24
Rated voltage U_r	20 ... 90 V DC / 48 ... 253 V AC 50 ... 60 Hz
Rated current I_r	approx. 100 mA
Power dissipation/power consumption	$\leq 1.8 \text{ W}$; 2 VA / 1.8 W ; 2 VA
Input	
Connection side	field side
Connection	Input I: 2-wire sensor: terminals 1+, 3- three wire sensor: terminals 1+, 2- and 3 input II: terminals 13+, 14- start-up override;
Input I	2- or 3-wire sensor, sensor acc. to EN 60947-5-6 (NAMUR) or mechanical contact
Open circuit voltage/short-circuit current	22 V / 40 mA
Input resistance	4.7 k Ω
Switching point/switching hysteresis	logic 1: > 2.5 mA ; logic 0: < 1.9 mA
Pulse duration	> 50 μs
Input frequency	0.001 ... 12000 Hz
Line fault detection	breakage I $\leq 0.15 \text{ mA}$; short-circuit I > 4 mA
Input II	startup override: 1 ... 1000 s, adjustable in steps of 1 s
Active/Passive	I > 4 mA (for min. 100 ms) / I < 1.5 mA
Open circuit voltage/short-circuit current	18 V / 5 mA
Output	
Connection side	control side
Connection	output I: terminals 10, 11, 12 output II: terminals 16, 17, 18
Output I, II	signal, relay
Contact loading	250 V AC / 2 A / $\cos \phi \geq 0.7$; 40 V DC / 2 A
Mechanical life	5×10^7 switching cycles
Energized/De-energized delay	approx. 20 ms / approx. 20 ms
Transfer characteristics	
Input I	
Measurement range	0.001 ... 12000 Hz
Resolution	0.1 % of measured value , $\geq 0.001 \text{ Hz}$
Accuracy	0.1 % of measured value , > 0.001 Hz
Measuring time	< 100 ms
Influence of ambient temperature	0.003 %/K (30 ppm)
Output I, II	
Response delay	$\leq 200 \text{ ms}$
Galvanic isolation	
Input I/other circuits	reinforced insulation according to IEC/EN 61010-1, rated insulation voltage 300 V _{eff}
Output I, II against eachother	reinforced insulation according to IEC/EN 61010-1, rated insulation voltage 300 V _{eff}
Output I, II/other circuits	reinforced insulation according to IEC/EN 61010-1, rated insulation voltage 300 V _{eff}
Start-up override/power supply	reinforced insulation according to IEC/EN 61010-1, rated insulation voltage 300 V _{eff}
Indicators/settings	
Display elements	LEDs , display
Control elements	Control panel
Configuration	via operating buttons
Labeling	space for labeling at the front
Directive conformity	
Electromagnetic compatibility	
Directive 2014/30/EU	EN 61326-1:2013 (industrial locations)
Low voltage	
Directive 2014/35/EU	EN 61010-1:2010
Conformity	
Electromagnetic compatibility	NE 21:2006
Degree of protection	IEC 60529:2001
Ambient conditions	
Ambient temperature	-20 ... 60 °C (-4 ... 140 °F)
Mechanical specifications	
Degree of protection	IP20
Connection	screw terminals

Release date 2017-09-12 15:15 Date of issue 2018-08-22 231209_eng.xml

Mass	300 g
Dimensions	40 x 119 x 115 mm (1.6 x 4.7 x 4.5 inch) , housing type C3
Mounting	on 35 mm DIN mounting rail acc. to EN 60715:2001
General information	
Supplementary information	Observe the certificates, declarations of conformity, instruction manuals, and manuals where applicable. For information see

Maximum Switching Power of Output Contacts

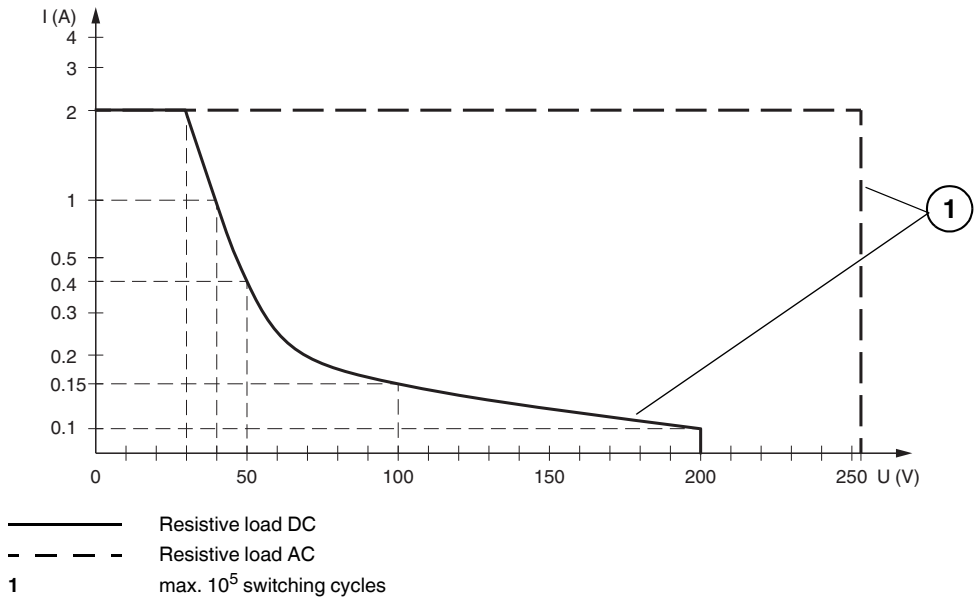

Release date 2017-09-12 15:15 Date of issue 2018-08-22 231209_eng.xml